



Syrris Ltd.
27 Jarman Way, Royston, Hertfordshire
SG8 5HW, United Kingdom
T: +44 (0)1763 242555
F: +44 (0)1763 242992
E: info@syrris.com
W: www.syrris.com

Syrris Limited
Registered office as address
Company No. 4257809

Subject	Assembly instructions for the filter vessel
Date	01/11/12
Author	Philip Podmore

Technical Note – Assembly instructions for the filter vessel

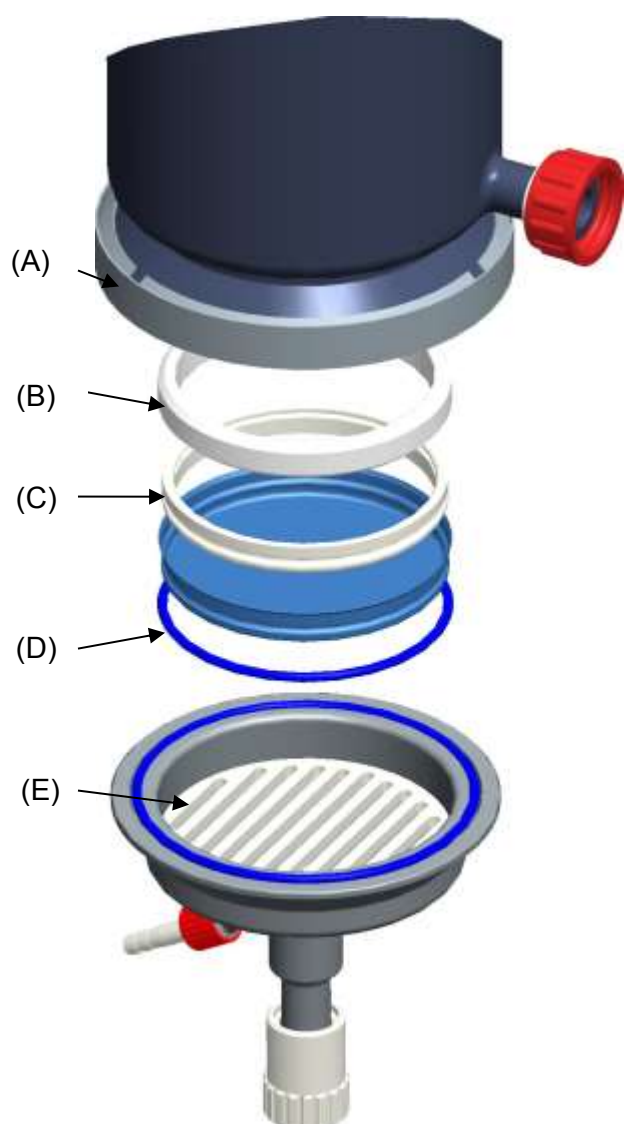

1. The filter paper is shown in blue in the Fig 1
2. The filter paper should be 150mm in diameter
3. Fold the filter paper around the PTFE ring (C) and secure it in place using the O-ring (D).
4. Place this assembly into the slotted support plate (E)
5. Place the ring support (B) over this assembly to centralise the base section relative to the main vessel.
6. Offer up the fully assembled base section to the main vessel and secured in place with the clamp (A)
7. The fully secured assembly is shown in cross section in Fig. 2

Figure 1: Exploded Diagram of Filter vessel assembly

BASE COMPONENTS
IN ASSEMBLED POSITIONS

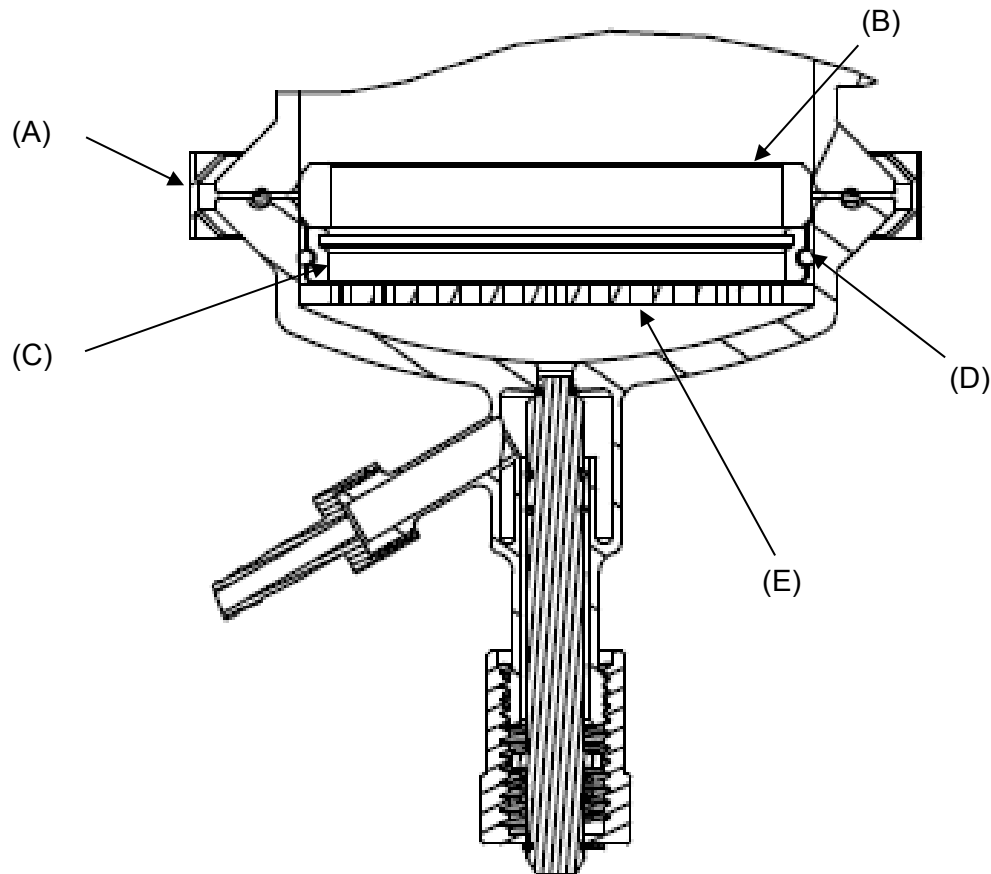

Figure 2: Fully secured assembly in cross-section

Legend:

- A: Quick-Release Clamp
- B: PTFE Ring Support
- C: PTFE Filter Paper Ring
- D: Filter Paper O-Ring
- E: Slotted Support Plate